

## **‘E’ Opto-Electrical Connector System Subsea / Underwater / Marine**

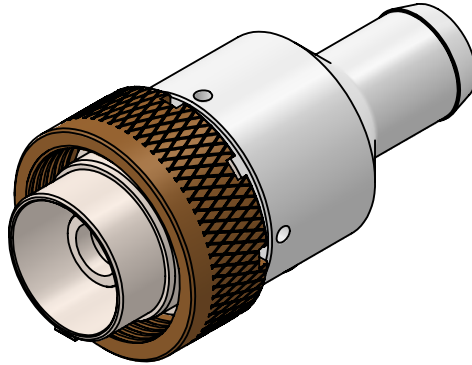

### **Introduction:**

CRE's range of metal shell Fibre Optic/Electrical Fully Sealed Connectors focus on delivering high reliability in tough environments. The design offers a high integrity sealing arrangement, metal keyways, along with our ability to design specific solutions for your application. They are designed for heavy duty use in the most rigorous underwater applications on the planet. Made of 316 stainless steel or custom built with any material specified, they come as standard with high open face pressure resistance. These robust and versatile connectors are rated to 4,000m and are designed for use with moulded or oil filled assemblies and tailored for the heaviest power, signal and electro-mechanical applications.

### **The most common applications:**

- ROV
- Dive Bell Connectors
- Underwater Thruster

### **Key Features:**

- Multi size shell body
- 12 contacts
- 1 & 2 Channel Configurations
- Multimode 50/125 and 62.5/125 versions
- Singlemode 9/125 Fibre
- Available as Patchcords and Pigtailed Bulkheads
- Right angled Plug End also available
- Pressure up to 6,000 Psi (Mated)
- Open face pressure up to 6000 Psi
- Oil filled available as standard (OF)
- Up to a working voltage of 1000 VDC dependant on pin/contact density and wire specification used.
- Up to 26amps - single pin see page 9



**Options:**

- Field Installable
- Bespoke design/configuration to suit customer requirements at no extra cost
- Available in alternative materials: Aluminium, Titanium etc.
- **Testing:**
  - Pressure testing up to 6,000 Psi
  - Durability testing with 100 mate and re-mate cycles
  - Open face pressure testing up to 6000 Psi

**Part Numbering System - Bulkhead Example**

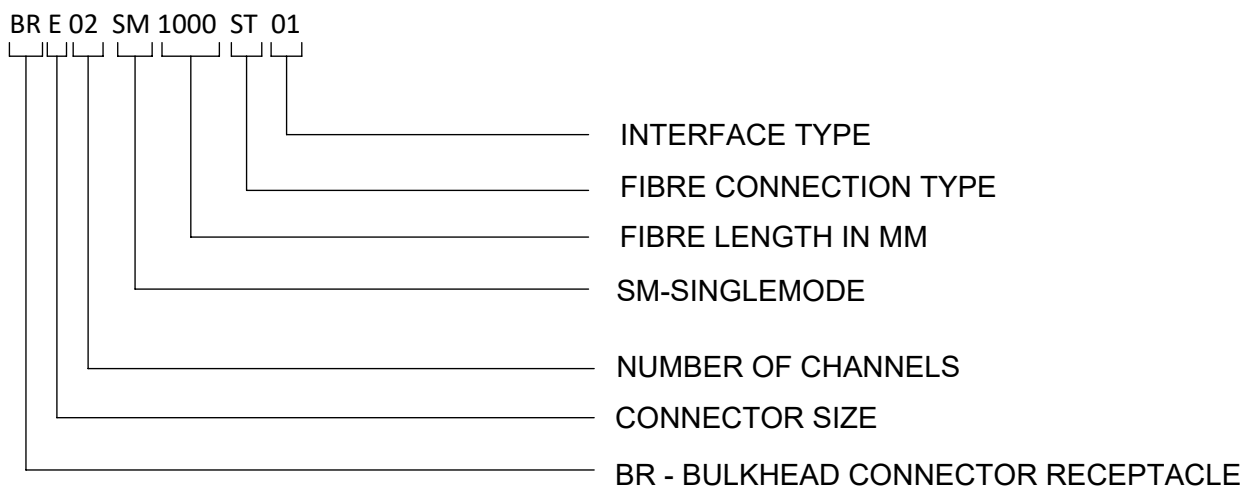

**Part Numbering System - Connector Example**

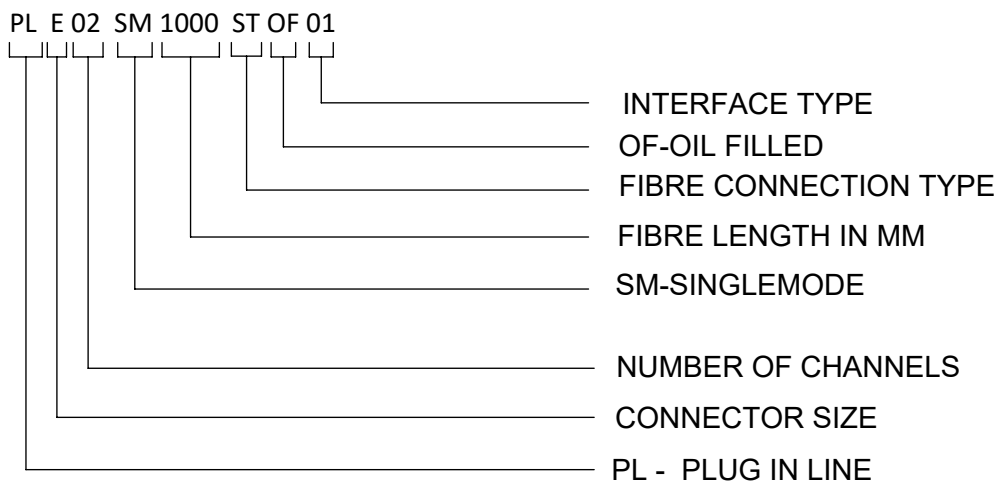



**Standard Mechanical Specification:**

COMPONENT	MATERIAL
Shell Body	Stainless Steel 316L
Retaining Nut	Stainless Steel/Aluminium Bronze
'O' Rings	Nitrile NI70
Contact Insert	Peek
Electrical Contacts	Leaded Nickel Copper C97 or K41
Plating Details	1um Acid Gold over 2.5um Nickel Copper Flash
Backing Washer	Black Acetal

Contact CRE for special order materials.

**Electrical and Enviromental:**

- Singlemode Insertion Loss: 9/125 Fibre @ 1,310nm/1,1550nm : Up To 2.0dB
- Multimode Insertion Loss: 50/125 & 62.5/125 @850nm/1300nm : Up To 1.0dB
- Operating Temperature: -40C to + 85C
- Storage Temperature: -55C to + 85C
- Durability: 2000 Matings minimum
- Depth Rating: 4000 Metres

**Fibre Characteristics:**

**Singlemode - 9/125 (SM)**

- Attenuation: 0.38dB/km @ 1,310nm
- Attenuation: 0.25dB/km @ 1,550nm
- Dispertion: 3.5ps/nm.km @ 1310nm
- Dispertion: 18.0ps/nm.km @ 1,550nm
- NA: 1.470

**Multimode - 50/125 (MM)**

- Attenuation: 2.8dB/km @ 850nm
- Attenuation: 0.8dB/km @ 1,300nm
- Bandwidth: 500MHz/km @ 850nm
- Bandwidth: 500MHz/km @1,300nm
- NA: 0.20
- 

**Multimode - 62.5/125 (MM)**

- Attenuation: 3.0dB/km @ 850nm
- Attenuation: 1.0dB/km @ 1,300nm
- Bandwidth: 200MHz/km @ 850nm
- Bandwidth: 500MHz/km @1,300nm
- NA: 0.27
-

# Reference Dimensions 'E' Opto-Electrical Connector

Flanged Bulkhead Connector Receptacle-Composite (FR)

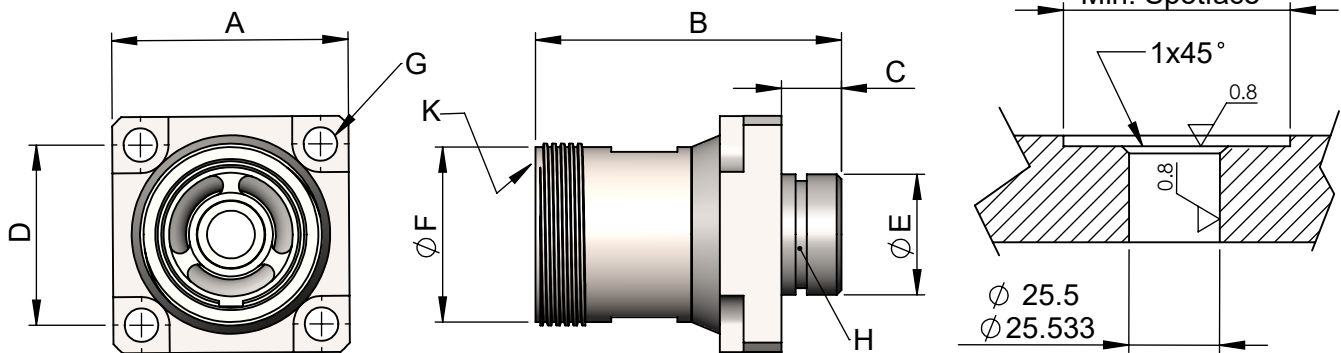
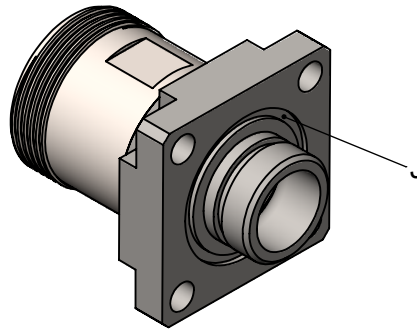

A	B	C	D	E	F	G	H-O'Ring	J-O'Ring	K-O'Rings	TYPE
50	64.7	12.7	38.1	25.5	37	7.1	BS020	BS026	31 x 2	01

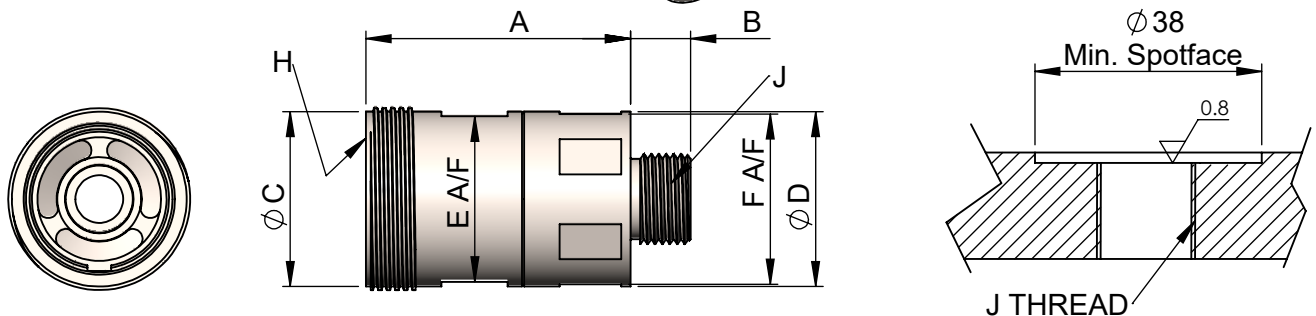
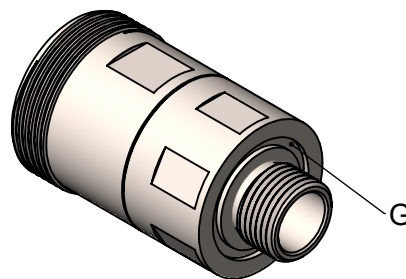

A	B	C	D	E	F	G-O'Ring	H-O'Ring	J THREAD	TYPE
56	12.7	37	37	35	36	BS021	31 x 2	3/4"-16 UNF	01

NOTE: For recommended Torque figures please refer to page 9

# Reference Dimensions 'E' Opto-Electrical Connector

Backshell Cable Connector Receptacle-Composite (PL)

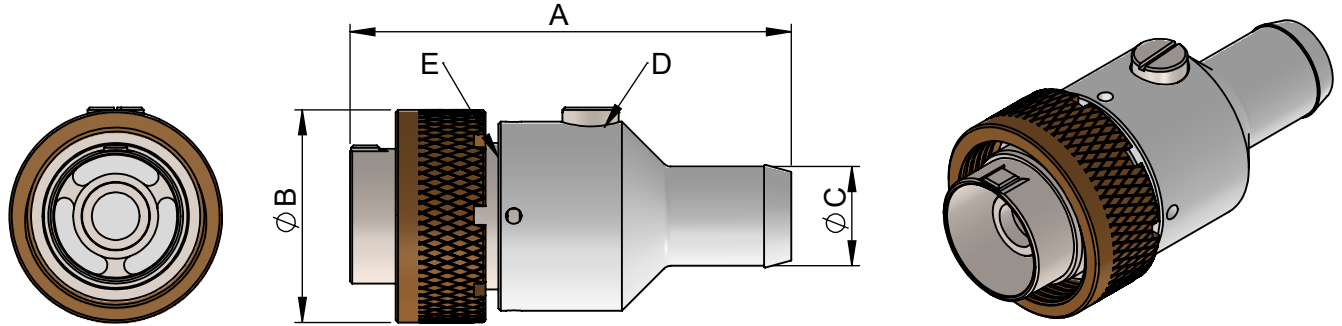

A	B	C	D-'O'Ring	E-'O'Ring	TYPE
93.5	45	21	6 x 1.5	30 x 2	01

# Reference Dimensions 'E' Opto-Electrical Connector

Bulkhead Blanking Plug - PLEBC

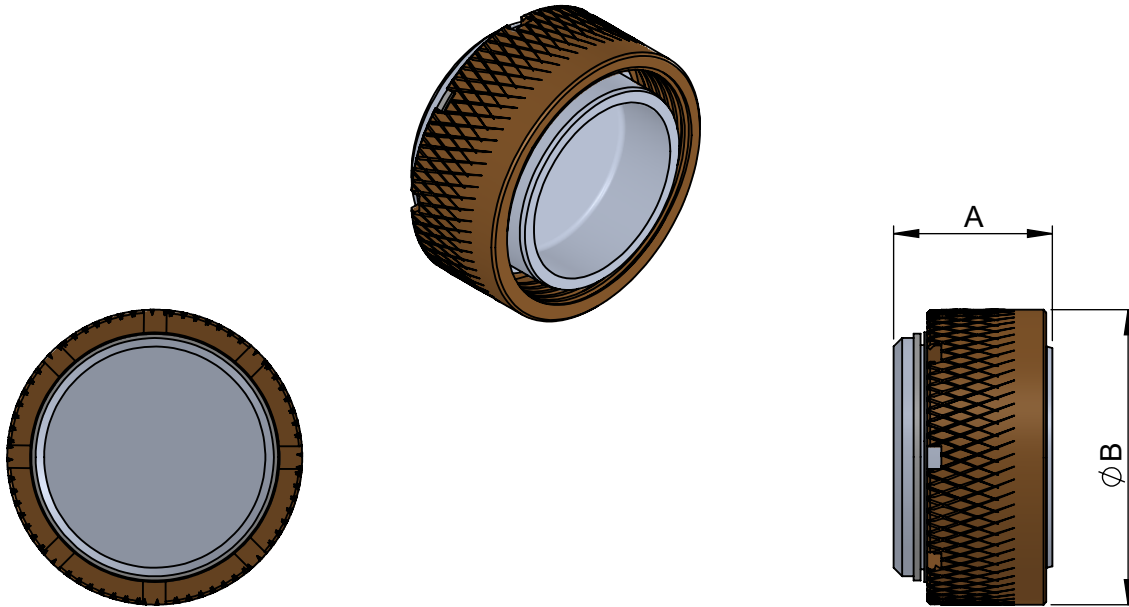

A	B
24.9	45

Cable Connector Blanking Plug - BREBC

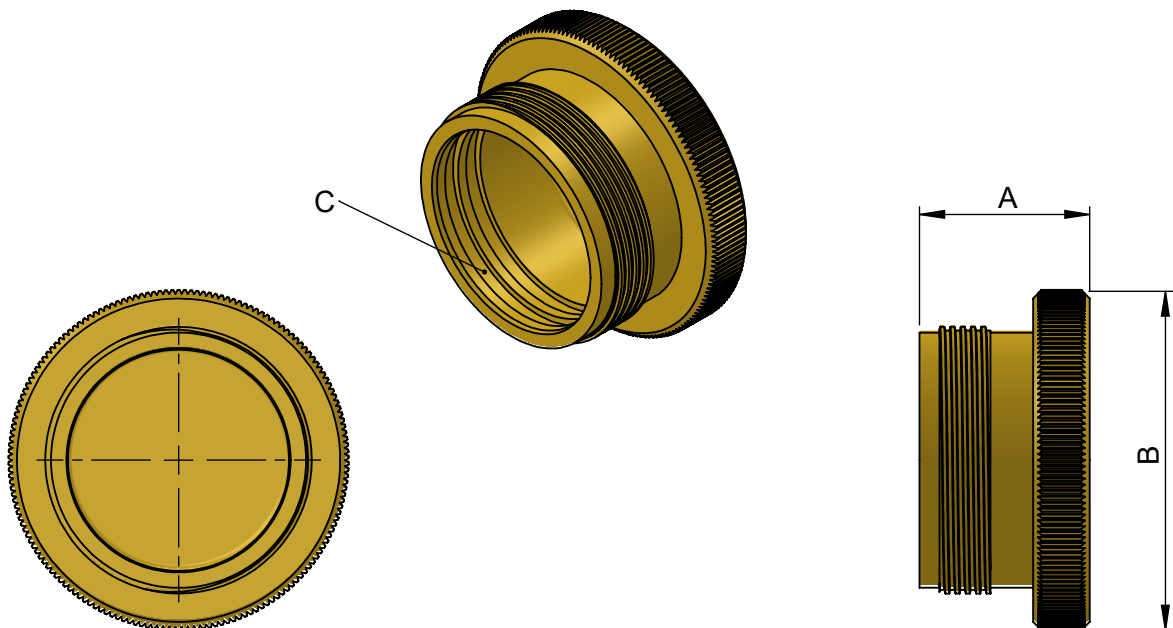

A	B	C-O'Ring
31	46	31 x 2

## Assembled Dimensions 'E' Opto-Electrical Connector

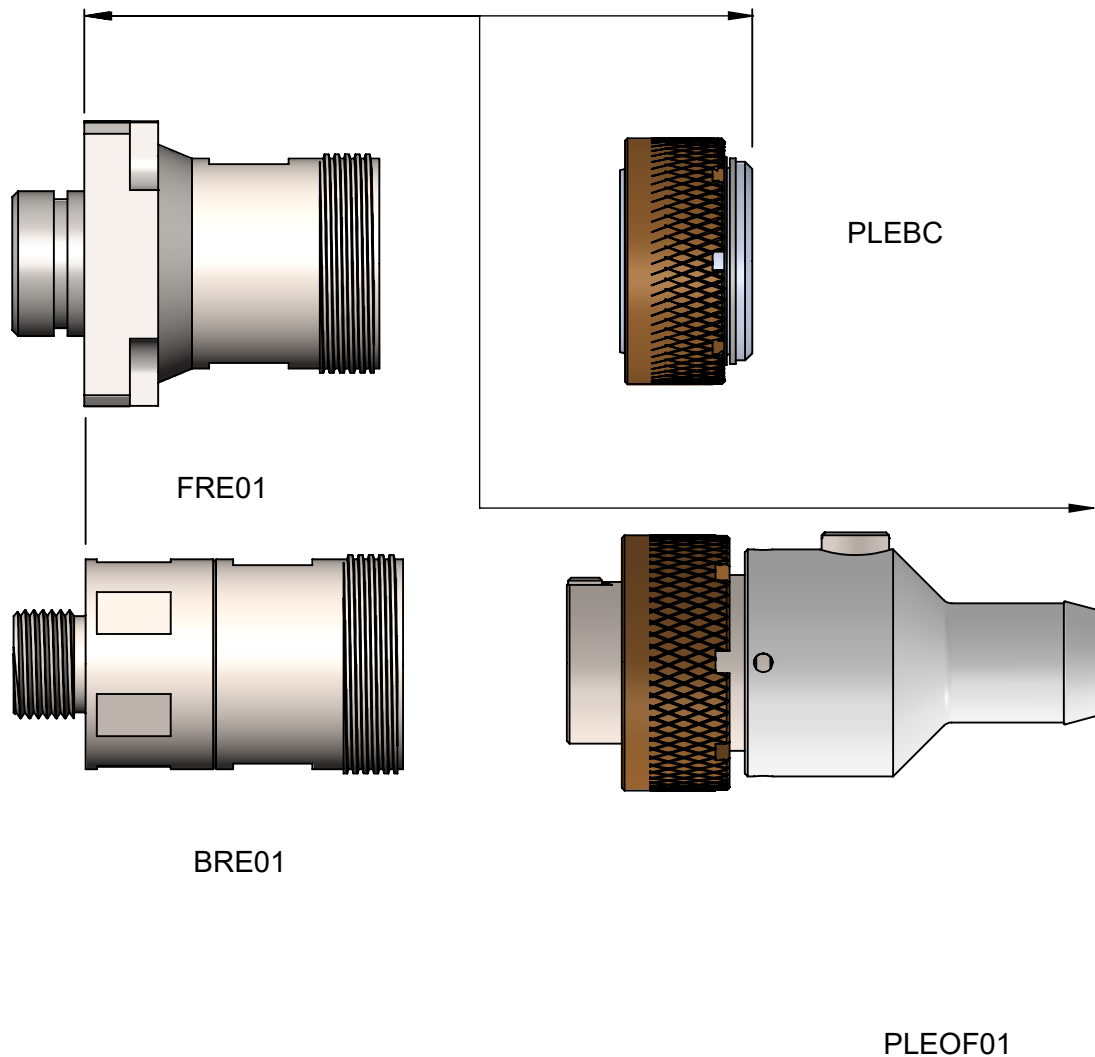

	PLEBC	PLEOF01
FRE01	63.5	126
BRE01	67.5	130

Note: Step files for design purposes available from engineering @CRE-marine.com

## Face View

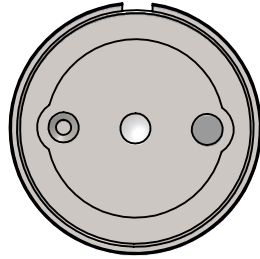

1 CHANNEL

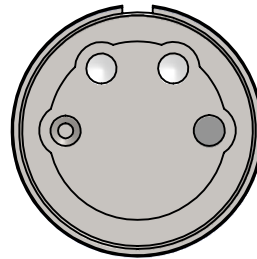

2 CHANNEL

FIBRE TYPE-----SM / MM

TAILS WITH CONNECTION TO SUIT-ST/SC ETC.

## Pin Face View

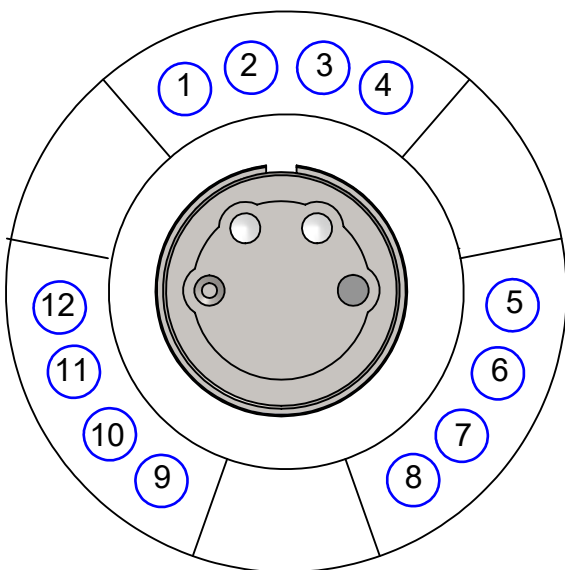

## Socket Face View

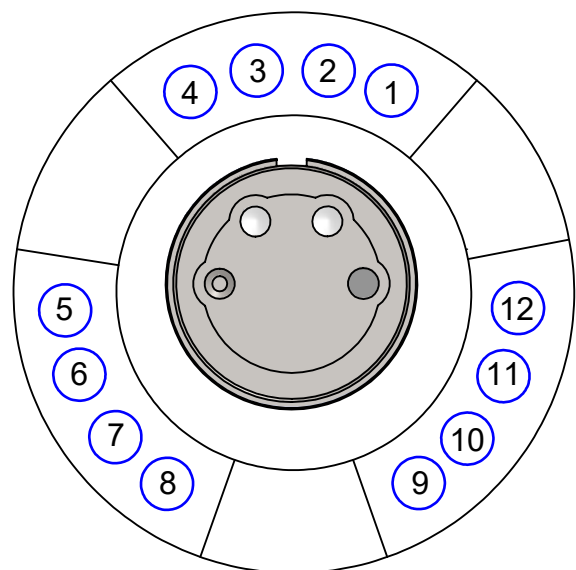

∅ 1.56 Pin

For current carrying capacity and wire recommendations see page 9



## Current Capacity and Wire Recommendations

- The current rating maybe impacted by cable selection and the ambient temperature.
- The amount of heat generated should not exceed the maximum temperature rating of the insulation material.
- Heat dissipation is lessened as the number of individually insulated conductors bundled together is increased.
- A derating factor must be applied for bundled conductors. See chart below.
- Current ratings shown below are for single conductors in free air at 30deg C ambient temp.
- Where applicable, alternative pin & current ratings are available.
- Up to a working voltage of 1000 VDC dependant on pin/contact density and wire specification used.
- For different pin configurations contact CRE

Pin Diameter	1.56
Wire Size	16 awg
Current	26 amps
Current ratings based on PTFE type C cable	

<b>Derating Factors for Bundled Conductors</b>	
Bundle #	Derating Factor ( x Amps )
2 - 5	0.8
6 - 15	0.7
16 - 30	0.5

**Notes:**

- Larger solder bucket options are not available on all contact configurations, please contact CRE Engineering to confirm your requirement is possible.
- Final wiring detail depends on through bore of Interface chosen, please contact CRE Engineering to confirm your requirement is possible.

## Recommended Torque figures for threaded Bulkheads and Low Profile Interfaces manufactured in 316L Stainless Steel

THREAD	TORQUE N/m (Lubricated)
3/4-16 UNF	27

The table above shows our recommended tightening torque values for the Size 'A' threaded Bulkheads and Low Profile Interfaces shown in these Datasheets.

We would recommend a small quantity of anti-seize lubricant such as Copaslip is used on the threads as a lubricant to aid the make up process.

CRE also supply Bulkheads manufactured from 6082-T6 Aluminium, Grade 5 Titanium

The same Torque figures can be applied for the Aluminium and Titanium materials.

Should you require any further information or advice then please contact CRE direct.